

KT-21 SERIES

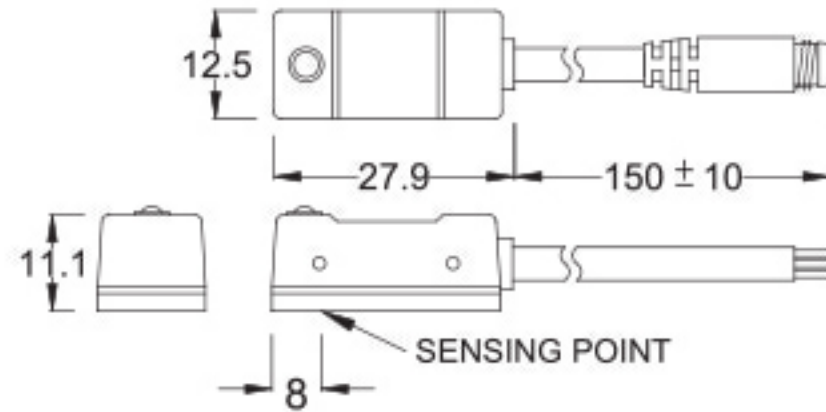

■ DIMENSIONS

KT-21N, KT-21P / KT-21N-QD, KT-21P-QD



KT-21R, KT-21D / KT-21R-QD, KT-21D-QD

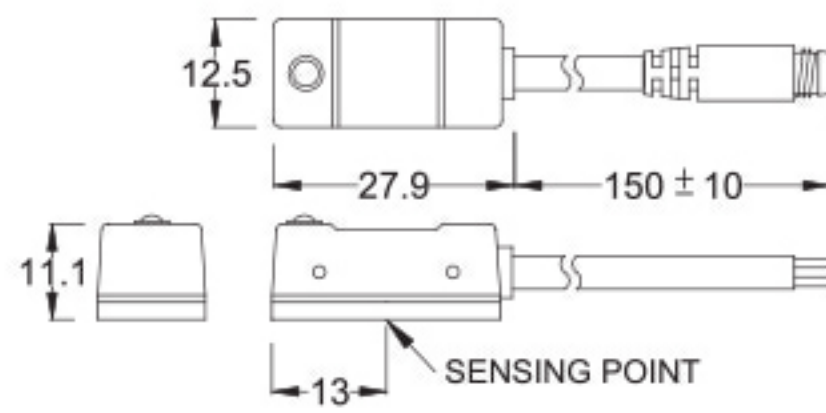

Unit:mm

■ QD PINOUT

*3 wire QD wiring

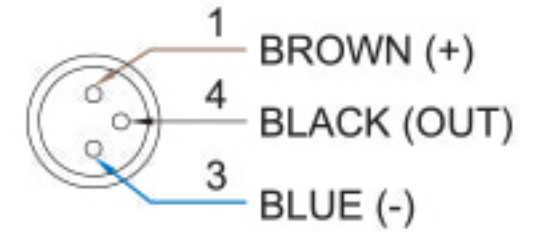

*2 wire QD wiring

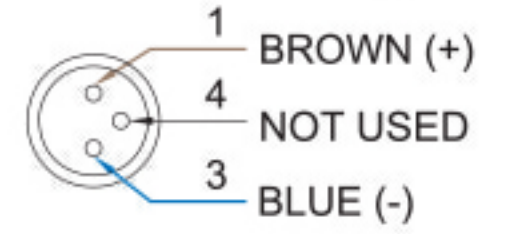

*2 wire EQD wiring

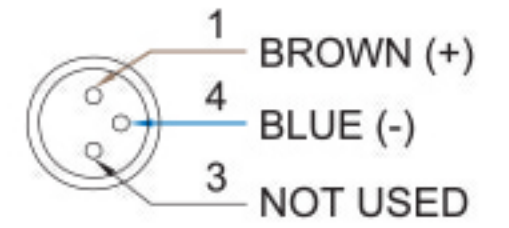

■ SPECIFICATIONS

TYPE	KT-21R	KT-21D	KT-21N	KT-21P
CONNECT DIAGRAM				
CHARACTERISTICS	2-Wire Type		3-Wire Type	
Wiring Method	2-Wire Type		3-Wire Type	
Switching Logic	SPST, Normally Open		Solid State Output, Normally Open	
Sensor Type	Reed Switch	-	NPN Current Sinking	PNP Current Sourcing
Operating Voltage	5~240V DC/AC	10~28V DC/AC	5~30V DC	
Switching Current	100mA max.	50mA max.	200 mA max.	
Contact Rating (*1)	10W max.	1.5W max.	6W max.	
Current Consumption	-		15mA @ 24V DC max.	
Voltage Drop	3.5V max.		1.5V max.	
Leakage Current	-	0.1 mA max.	0.01 mA max.	
Indicator	Green LED	Red LED		Green LED
Cable	ø4, 2C, PVC		ø4, 3C, PVC	
Operating Frequency	200Hz	400Hz	1000 Hz	
Magnet Requirement (*2)	80Gauss	50Gauss	70Gauss	
Temperature Range	-10~70°C			
Shock (*3)	30G		50G	
Vibration (*4)	9G			
Enclosure Classification	IEC 60529 IP67			
Protection Circuit (*5)	1	3,4	2,3,4	

NOTE:

1. WARNING: Never exceed rating (Watt=Voltage x Amperage). Permanent damage to sensor will occur.
2. Measuring standard target: ø15.5Xø8X5t (Anisotropy rubber magnet)
3. Sin wave / X, Y, Z 3 directions / 3 times each direction / 11 ms each time.
4. Double amplitude 1.5 mm / 10Hz~55Hz~10Hz (Sweep 1 min) / X, Y, Z 3 directions / 1 hour each time.
5. 1=None / 2=Short-circuit / 3=Power Source Reverse polarity / 4=Surge Suppression

KT-20 & KT-21 series can be applied to many kind of cylinders

