

▶ MJ2 SERIES MICRO SWITCHES

◆ FEATURES

- Regular or sealed operating heads.
- Momentary contacts.
- Completely sealed constructure.
- Wide choice of heads and actuators.
- Plastic(Standard) or phenolic housing.
- Regular or light operating force. / —
- Temperature range +5°F to +175°F (-15°C to +80°C).
- Soldering Terminal or Fast Terminal



● MJ2-1308

◆ CIRCUITRY

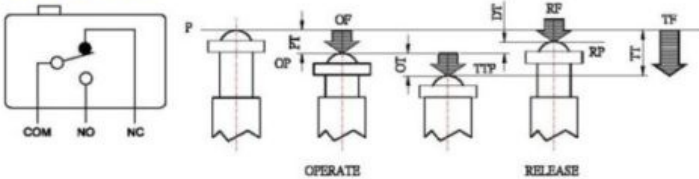

OF : Operating Force
 RF : Releasing Force
 TF : Total Force
 FP : Free Position
 OP : Operating Position
 RP : Releasing Position

TTP : Total Travel Position
 PT : Pretravel
 OT : Overtravel
 DT : Travel Differential
 TT : Total Travel

◆ CHARACTERISTICS

Operating speed	0.01mm to 1m/sec
Operating frequency	Mechanically: 240 operations/min. Electrically: 20 operations/min.
Contact resistance	15m Ω max. (Initial)
Insulation resistance	100M Ω min. (at 500 VDC)
Dielectric strength	1,000 VAC, 50/60 Hz for 1 minute between non-continuous terminals 2,000 VAC, 50/60 Hz for 1 minute between current-carry part and ground
Vibration	Malfunction durability: 10 to 55Hz 1.5mm double amplitude
Shock	Mechanical durability: Approx. 1,000m/sec ² (approx. 100G's) Malfunction durability: Approx. 300 m/sec ² (approx. 30G's)
Ambient operating temperature	General purpose type: -25° to + 80°C Sealed type: -15 to 80°C
Humidity	General purpose type: 85% RH max Sealed type: 95% RH
Service life	Mechanically: 20,000,000 operations min Electrically: 500,000 operations min.



● MJ2-1317



● MJ2-1513



● MJ2-1307-P



● MJ2-1300



● MJ2-1306-P



● MJ2-1308R-P



● MJ2-1307



● MJ2-1305



● MJ2-1514



● MJ2-1308-P



● MJ2-1515



● MJ2-1308R



● MJ2-1306

◆ RATING

15A	125 or 250V AC
1/8 HP	125 V AC
1/4 HP	250 V AC
1/2 A	125 V DC
1/4 A	250 V DC

◆ REMARK

- OIL TIGHT SERIES
 MJ2-1315 MJ2-1317
 MJ2-1513 MJ2-1514 MJ2-1515
 MJ2-1711 MJ2-1712 MJ2-1713 MJ2-1714
- SENSITIVITY ADJUSTABLE SERIES
 MJ2-1513 MJ2-1514 MJ2-1543 MJ2-1544
 MJ2-1701 MJ2-1702 MJ2-1703 MJ2-1704
 MJ2-1711 MJ2-1712 MJ2-1713 MJ2-1714

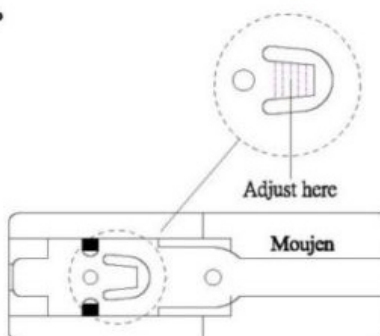

● MJ2-1315

ORDER GUIDE

DIMENSIONS (mm) OPERATING CHARACTERISTICS

MJ2-1300

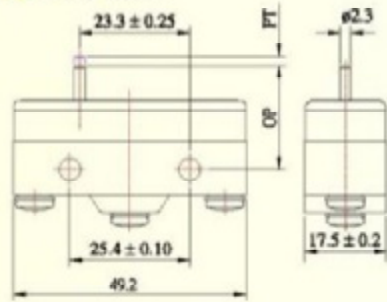

	MJ2-1300	MJ2-1300L
OF MAX	250-450g	200g
RF MIN	114g	
PT MAX	0.5mm	
OT MIN	0.13mm	
DT MAX	0.05mm	
FP MAX		
OP	15.9±0.4mm	

DIMENSIONS (mm) OPERATING CHARACTERISTICS

MJ2-1315

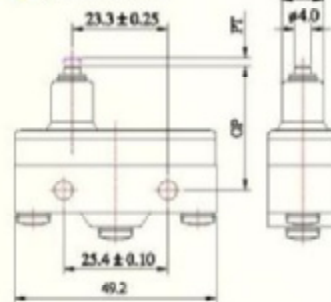

	MJ2-1315
OF MAX	540g
RF MIN	114g
PT MAX	1.9mm
OT MIN	1.6mm
DT MAX	0.06mm
FP MAX	
OP	28.2±0.5mm

MJ2-1305

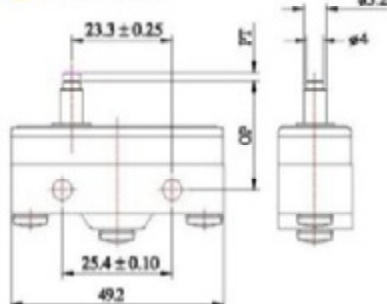

	MJ2-1305	MJ2-1305L
OF MAX	250-450g	200g
RF MIN	114g	
PT MAX	0.5mm	
OT MIN	1.6mm	
DT MAX	0.05mm	
FP MAX		
OP	26.2±0.5mm	

MJ2-1317

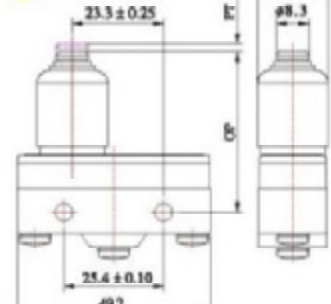

	MJ2-1317
OF MAX	540g
RF MIN	114g
PT MAX	2.4mm
OT MIN	3.5mm
DT MAX	0.06mm
FP MAX	
OP	36.1±1.2mm

MJ2-1306

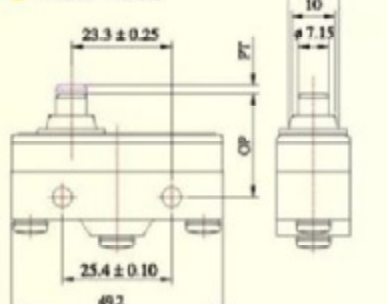

	MJ2-1306	MJ2-1306L
OF MAX	250-450g	200g
RF MIN	114g	
PT MAX	0.5mm	
OT MIN	1.6mm	
DT MAX	0.05mm	
FP MAX		
OP	21.5±0.5mm	

MJ2-1513

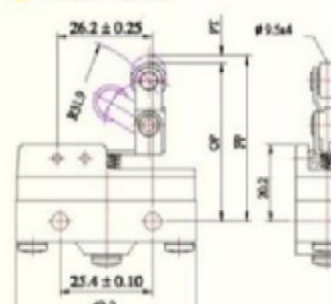

	MJ2-1513
OF MAX	180g
RF MIN	50g
PT MAX	2.7mm
OT MIN	2.4mm
DT MAX	0.8mm
FP MAX	43.6mm
OP	41.3±0.8mm

MJ2-1307

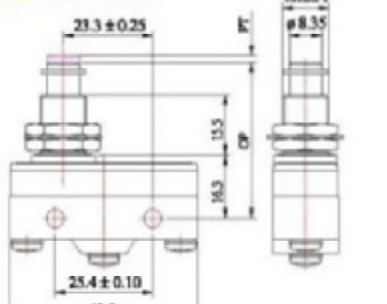

	MJ2-1307	MJ2-1307L
OF MAX	250-450g	200g
RF MIN	114g	
PT MAX	0.5mm	
OT MIN	5.5mm	
DT MAX	0.05mm	
FP MAX		
OP	36.1±0.6mm	

MJ2-1514

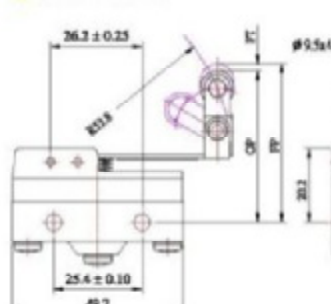

	MJ2-1514
OF MAX	150g
RF MIN	25g
PT MAX	6.4mm
OT MIN	4.0mm
DT MAX	1.6mm
FP MAX	47.2mm
OP	41.3±0.8mm

MJ2-1308

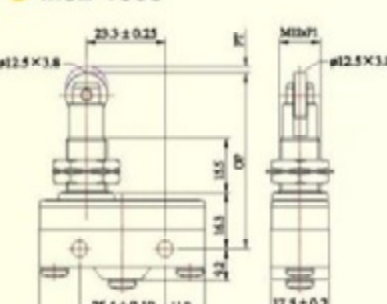

	MJ2-1308	MJ2-1308L
OF MAX	250-450g	200g
RF MIN	114g	
PT MAX	0.5mm	
OT MIN	3.58mm	
DT MAX	0.05mm	
FP MAX		
OP	49.7±1.2mm	

MJ2-1515

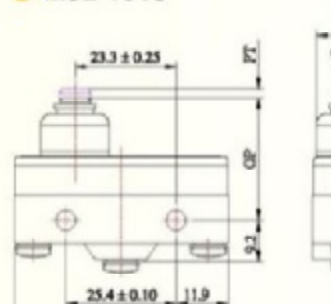

	MJ2-1515
OF MAX	540g
RF MIN	114g
PT MAX	2.3mm
OT MIN	1.6mm
DT MAX	0.06mm
FP MAX	
OP	28.2±0.5mm

*2 ho x agon mat thickness: 3mm

*2 ho x agon mat thickness: 3mm

▶ MJ2 SERIES MICRO SWITCHES

◆ ORDER GUIDE

● Plastic body(Standard Type)

MJ2-1280	MJ2-1300	MJ2-1305	MJ2-1306	MJ2-1307	MJ2-1308	MJ2-1308R	MJ2-1543	MJ2-1544
MJ2-1578	MJ2-1701	MJ2-1702	MJ2-1703	MJ2-1704	MJ2-1315	MJ2-1317	MJ2-1513	MJ2-1514
MJ2-1515	MJ2-1711	MJ2-1712	MJ2-1713	MJ2-1714	MJ2-CB2	MJ2-1703-F (metal roller)		
MJ2-1704-F (metal roller)			MJ2-1730	MJ2-1732	MJ2-1737	MJ2-1737-F(metal roller)		



● MJ2-1543

● Type Number Ordering Code

MJ2- 1 2 8 0

① ② ③ ④ ⑤ ⑥

① Series basic definition code MJ2 -

② Façture type number

1280~1744 set up ordinal number according to different driving devices.
Please refer to type picture and type number in the catalogue.
1280~1744

③ Body(case) material type

Non-indicate : Plastic Body (standard)
P : Phenolic Body(custom made)

④ OF(operating force) type OF

Non-indicate : Normal force(standard)
L : Light force(custom made)

⑤ Terminal type

Non-indicate : Only attached screw(standard)

S : Soldering Terminal Type (custom made)

A : Fast Terminal Type(custom made)

⑥ Roller or head material type

- F : Metal roller(custom made)

- P : Plastic(POM) roller、head(custom made)



ORDER GUIDE

DIMENSIONS (mm) OPERATING CHARACTERISTICS

● MJ2-1543

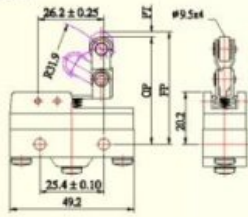

	MJ2-1543	MJ2-1543L
OF MAX	170g	120g
RF MIN	42g	
PT MAX	2.7mm	
OT MIN	2.4mm	
DT MAX	0.51mm	
FP MAX	43.6mm	
OP	41.3±0.8mm	

● MJ2-1544

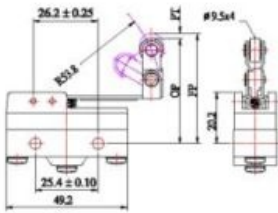

	MJ2-1544	MJ2-1544L
OF MAX	110g	70g
RF MIN	25g	
PT MAX	6.4mm	
OT MIN	4.0mm	
DT MAX	1.6mm	
FP MAX	47.2mm	
OP	41.3±0.8mm	

● MJ2-1578

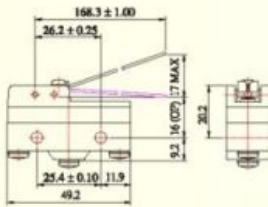

	MJ2-1578	MJ2-1578L
OF MAX	10g	5g
RF MIN	5g	
PT MAX	10mm	
OT MIN	6mm	
DT MAX	3mm	
FP MAX		
OP	20±1mm	

● MJ2-1701

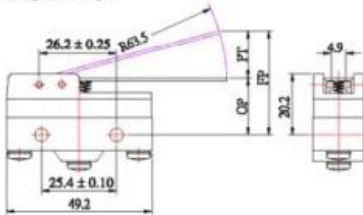

	MJ2-1701	MJ2-1701L
OF MAX	70g	40g
RF MIN	14g	
PT MAX	10mm	
OT MIN	5.6mm	
DT MAX	1.27mm	
FP MAX	28.2mm	
OP	19±0.8mm	

● MJ2-1702

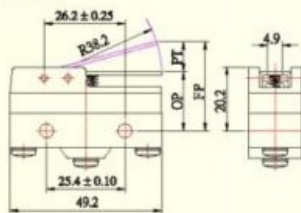

	MJ2-1702	MJ2-1702L
OF MAX	120g	80g
RF MIN	20g	
PT MAX	7.9mm	
OT MIN	3.0mm	
DT MAX	1.0mm	
FP MAX	26.2mm	
OP	19±0.8mm	

● MJ2-1703

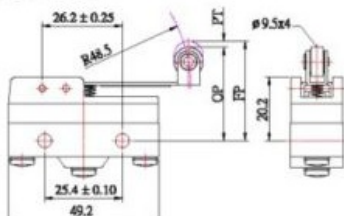

	MJ2-1703	MJ2-1703L
OF MAX	100g	60g
RF MIN	21g	
PT MAX	7.1mm	
OT MIN	4.0mm	
DT MAX	1.8mm	
FP MAX	36.5mm	
OP	30.2±0.8mm	

● MJ2-1704

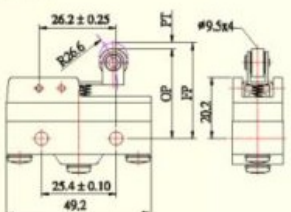

	MJ2-1704	MJ2-1704L
OF MAX	160g	110g
RF MIN	42g	
PT MAX	3.5mm	
OT MIN	2.4mm	
DT MAX	0.5mm	
FP MAX	34.5mm	
OP	30.2±0.8mm	

DIMENSIONS (mm) OPERATING CHARACTERISTICS

● MJ2-1711

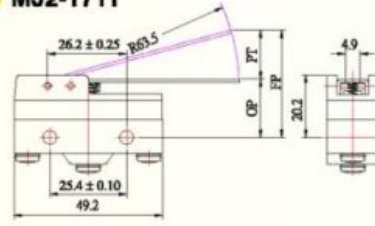

	MJ2-1711
OF MAX	100g
RF MIN	14g
PT MAX	10mm
OT MIN	5.6mm
DT MAX	2.0mm
FP MAX	28.2mm
OP	19±0.8mm

● MJ2-1712

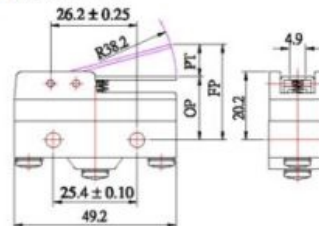

	MJ2-1712
OF MAX	150g
RF MIN	23g
PT MAX	7.9mm
OT MIN	3.0mm
DT MAX	1.5mm
FP MAX	26.2mm
OP	19±0.8mm

● MJ2-1713

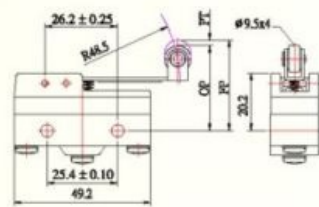

	MJ2-1713
OF MAX	130g
RF MIN	21g
PT MAX	7.1mm
OT MIN	4.0mm
DT MAX	1.6mm
FP MAX	36.5mm
OP	30.2±0.8mm

● MJ2-1714

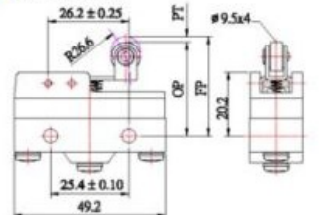

	MJ2-1714
OF MAX	200g
RF MIN	42g
PT MAX	3.5mm
OT MIN	2.4mm
DT MAX	0.5mm
FP MAX	34.5mm
OP	30.2±0.8mm

● MJ2-1730

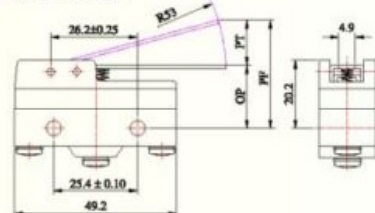

	MJ2-1730
OF MAX	90g
RF MIN	16g
PT MAX	9mm
OT MIN	4.8mm
DT MAX	1.15mm
FP MAX	27.2mm
OP	19±0.8mm

● MJ2-1732

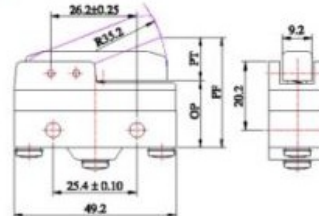

	MJ2-1732
OF MAX	180g
RF MIN	40g
PT MAX	6.0mm
OT MIN	1.4mm
DT MAX	1.5mm
FP MAX	30.1mm
OP	24.5±0.8mm

● MJ2-1737

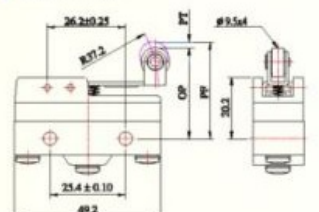

	MJ2-1737
OF MAX	125g
RF MIN	33g
PT MAX	5.7mm
OT MIN	3.4mm
DT MAX	1.1mm
FP MAX	35.8mm
OP	30.2±0.8mm