



Main

Range of product	Preventa Safety detection
Product or component type	Preventa RFID safety switch
Component name	XCSRC

Complementary

Design	Rectangular, standard
Size	Transponder: 50 x 15 x 15 mm Reader: 108.3 x 30 x 15 mm
Material	Valox
Electrical connection	1 male connector
Connector type	M12 male
Type of output stage	Solid-state, PNP
Safety outputs	2 NO
Number of poles	5
Local signalling	Green, orange and red 2 multi-colour LEDs
[Sao] assured operating sensing distance	10 mm face to face
[Sar] assured release sensing distance	35 mm face to face
Approach directions	3 directions-transponder with rotary sensing face
[Ue] rated operational voltage	24 V DC (- 20...10 %)SELV or PELV conforming to EN/IEC 60204-1
[Ie] rated operational current	60 mA
[Ui] rated insulation voltage	30 V DC
[Uimp] rated impulse withstand voltage	0.8 kV IEC 60947-5-2
Protection type	Short-circuit protection
Maximum switching voltage	26.4 V DC
Switching capacity in mA	200 mA

Disclaimer: This documentation is not intended as a substitute for and is not to be used for determining suitability or reliability of these products for specific user applications

Switching frequency	<= 0.5 Hz
Risk time	120 ms
Response time	120 ms typical
Maximum delay first up	5 s
Tightening torque	< 1.5 N.m
Standards	EN/IEC 60947-5-2 ISO 14119 EN/IEC 60947-5-3
Product certifications	EAC TÜV FCC IC CSA 22-2 Ecolab E2 RCM
Marking	FCC TÜV RCM EAC IC CE CULus
Safety level	SIL 3 conforming to EN/IEC 61508 SILCL 3 conforming to EN/IEC 62061 PL = e conforming to EN/ISO 13849-1 Category 4 conforming to EN/ISO 13849-1
Safety reliability data	PFH_D = 5E-10/h conforming to EN/IEC 62061 PFH_D = 5E-10/h conforming to EN/ISO 13849-1
Mission time	20 year(s)
Ambient air temperature for operation	-25...70 °C
Ambient air temperature for storage	-40...85 °C
Vibration resistance	10 gn (f= 10...150 Hz) conforming to EN/IEC 60068-2-6
Shock resistance	30 gn for 11 ms conforming to EN/IEC 60068-2-27
Electrical shock protection class	Class III conforming to EN/IEC 61140
IP degree of protection	IP65 conforming to EN/IEC 60529 IP66 conforming to EN/IEC 60529 IP67 conforming to EN/IEC 60529 IP69K conforming to DIN 40050

Packing Units

Unit Type of Package 1	PCE
Number of Units in Package 1	1
Package 1 Weight	106 g
Package 1 Height	3.7 cm
Package 1 width	14.9 cm
Package 1 Length	18 cm
Unit Type of Package 2	S01
Number of Units in Package 2	12
Package 2 Weight	1.427 kg
Package 2 Height	15 cm
Package 2 width	15 cm
Package 2 Length	40 cm

Offer Sustainability

Sustainable offer status	Green Premium product
EU RoHS Directive	Pro-active compliance (Product out of EU RoHS legal scope) EU RoHS Declaration
Mercury free	Yes

RoHS exemption information	Yes
Environmental Disclosure	Product Environmental Profile

Dimensions

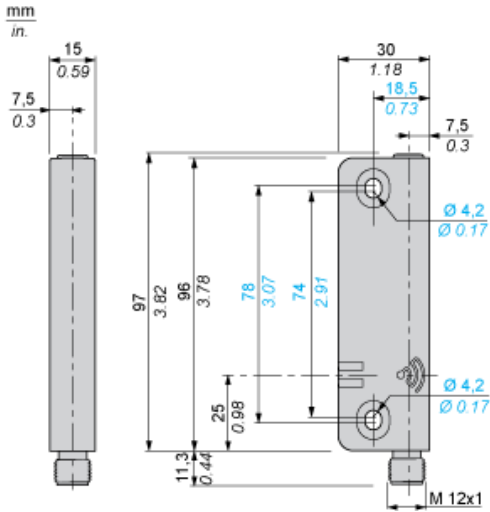

Connections

M12 Connector, 5-pin

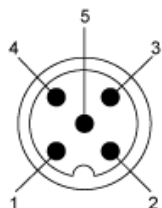

- (1) + 24 VDC
- (2) OSSD2
- (3) 0 VDC
- (4) OSSD1
- (5) NC (Not connected)

Connections

Wiring Diagram: Connection to a Safety Relay

Cat. 4 / PL=e (EN/ISO 13849-1) / SIL3 (IEC 61508) / SILCL3 IEC 62061), if combined with an appropriate Preventa XPS Safety unit PL=e / SIL3

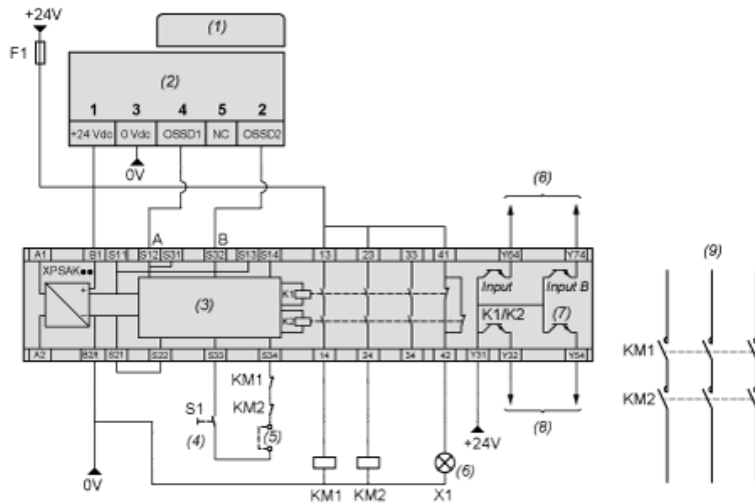

- (1) Transponder
- (2) Reader
- (3) Logic
- (4) Start
- (5) ESC: External start conditions
- (6) H1: indicator light deactivated
- (7) Fuse. Operating status of internal electronic fuse
- (8) To PLC
- (9) Power circuit

NOTE: KM1 and KM2 contactors must have force-guided contacts.

Connections

Wiring Diagram: Connection to a Safety Controller

Cat. 4 / PL=e (EN/ISO 13849-1) / SIL3 (IEC 61508) / SILCL3 IEC 62061), if combined with an appropriate Preventa XPS Safety controller PL=e / SIL3

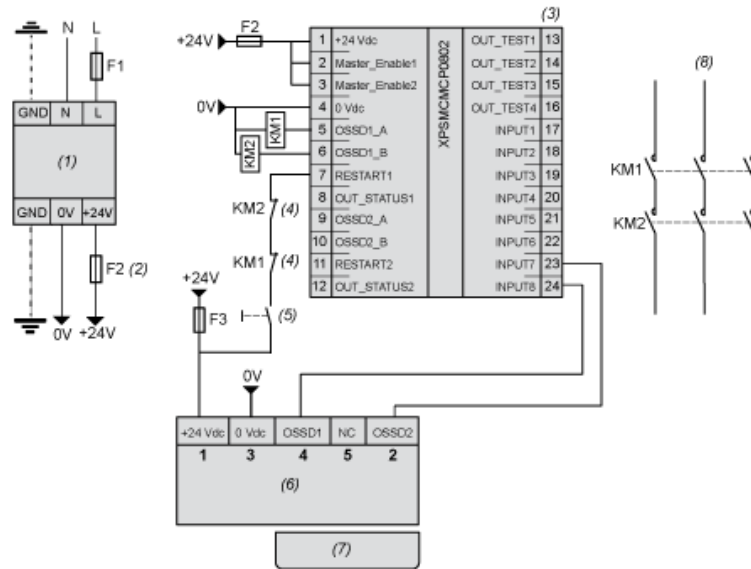

- (1) Power supply
- (2) 1 A max.
- (3) Safety controller
- (4) Feedback
- (5) Restart
- (6) Reader
- (7) Transponder
- (8) Power circuit

NOTE: KM1 and KM2 contactors must have force-guided contacts.

Mounting and Clearance

Face to Face Mounting (Preferred Configuration)

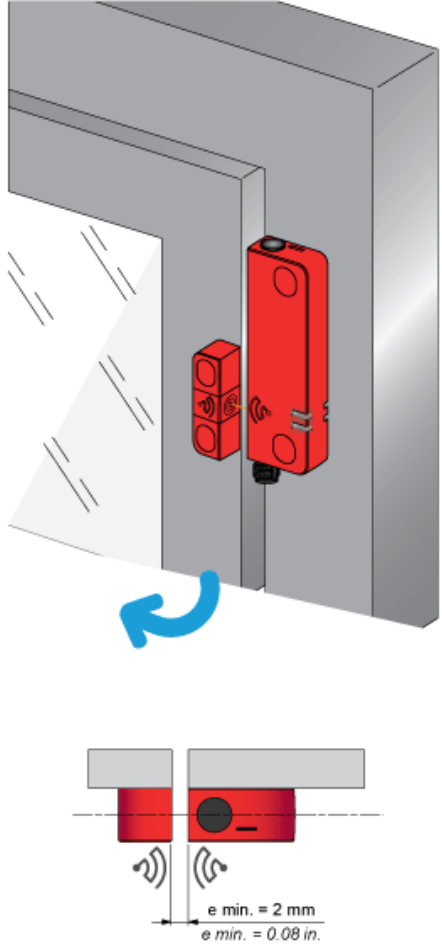
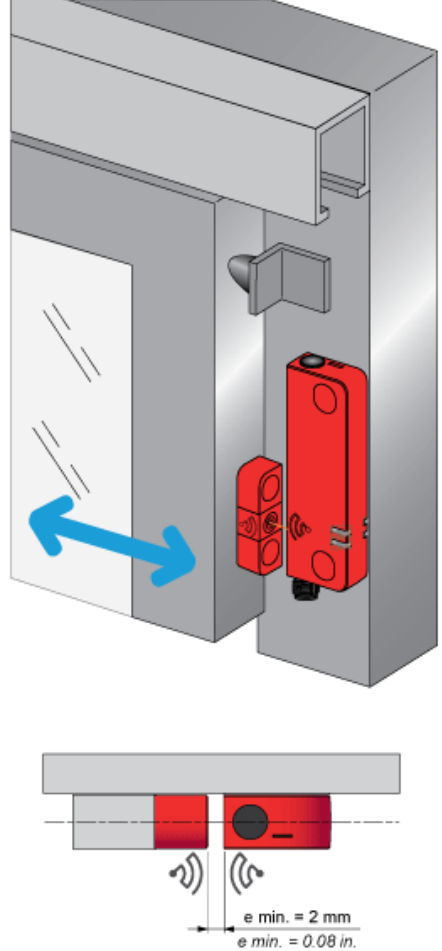
Example n°1	Example n°2
 <p>e: Recommended minimum mounting distance between transponder and reader</p>	 <p>e: Recommended minimum mounting distance between transponder and reader</p>

Face to Face Mounting (Preferred Configuration)

Example n°3

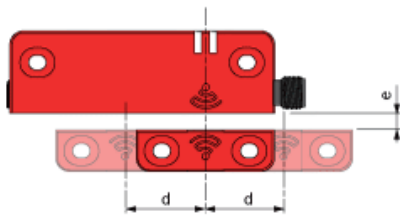
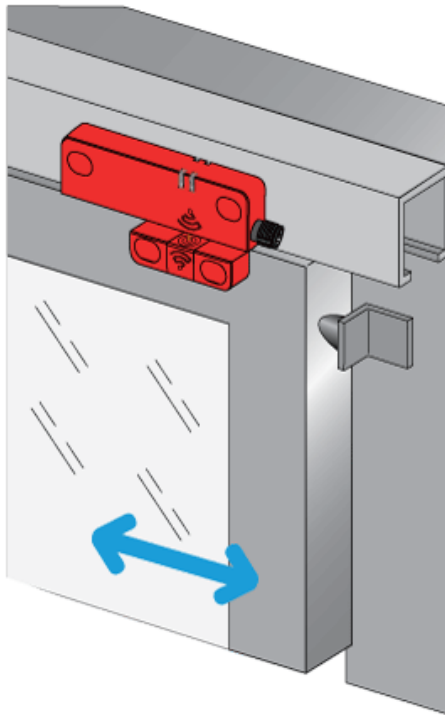

e min. > 2 mm. (e: recommended minimum mounting distance between transponder and reader)
d : Detection limit

Mounting and Clearance

Side by Side Mounting

Correct Mounting Configuration

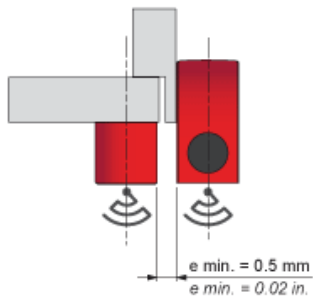
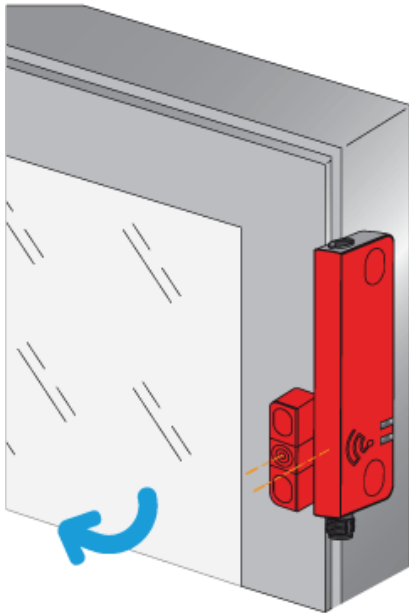

e: Recommended minimum mounting distance between transponder and reader.

Mounting and Clearance

Minimum Mounting Clearances between Safety Switches

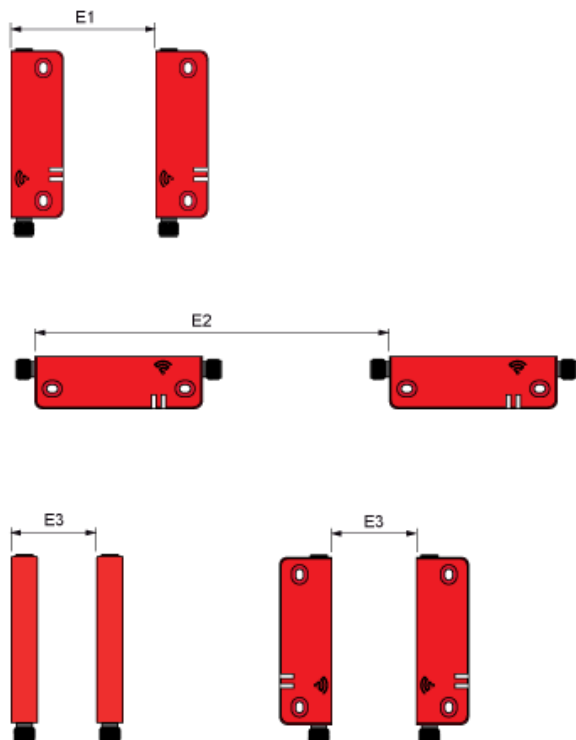

Dimensions in mm

E1 min.	E2 min.	E3 min.
45	150	65

Dimensions in in.

E1 min.	E2 min.	E3 min.
1.77	5.91	2.56

Detection Curves

Face to Face Mounting (Preferred Configuration)

Sao and Sar sensing distances along Y axis as function of Z (longitudinal misalignment for X=0)

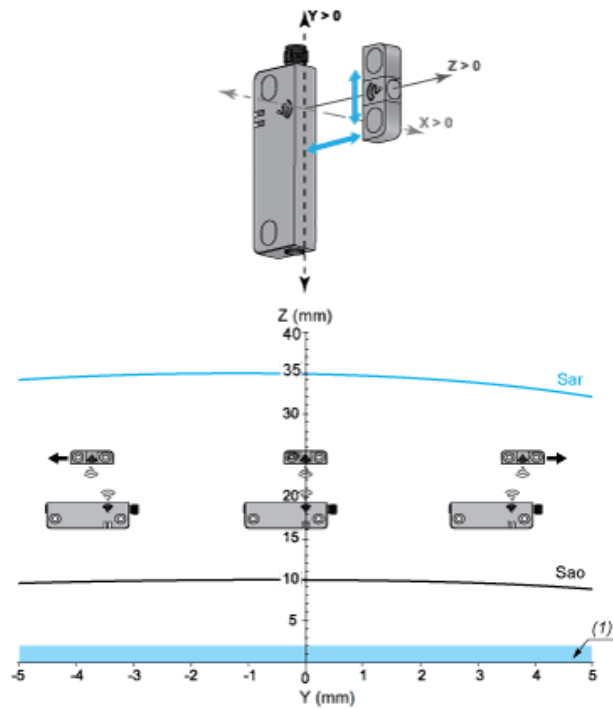

- Sar: Assured release distance
- Sao: Assured operating distance
- (1) Recommended minimum mounting distance between transponder and reader.

Sao and Sar sensing distances along X axis as function of Z (transverse misalignment for Y=0)

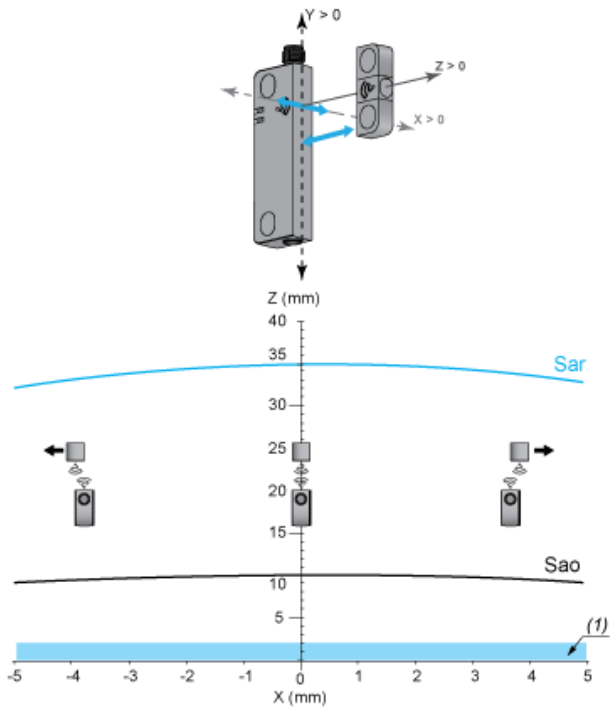

- Sar: Assured release distance
- Sao: Assured operating distance
- (1) Recommended minimum mounting distance between transponder and reader.

Detection Curves

Side by Side Mounting

Sao and Sar sensing distances along Y axis as function of X (longitudinal misalignment for Z=0mm)

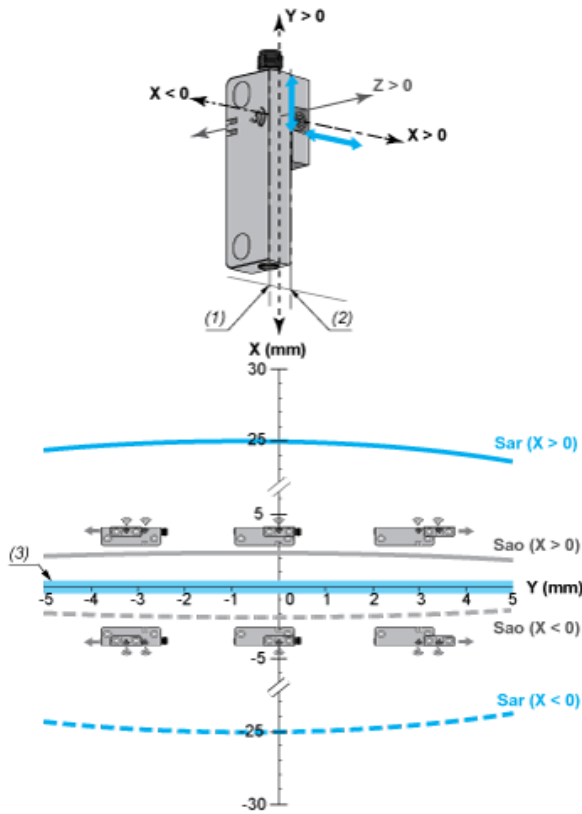

- Sar: Assured release distance
- Sao: Assured operating distance
- (1) X=0 for X<0
- (2) X=0 for X>0
- (3) Recommended minimum mounting distance between transponder and reader.

Sao and Sar sensing distances along Z axis as function of X (transverse misalignment for Y=0mm)

