

3 PHASE DC TO AC SSR

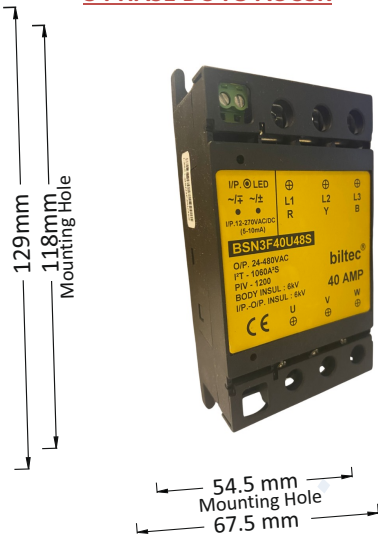

Current upto 36 Amp @40°C
with Din Rail 42mm
 $\Delta T = 75^\circ C$
Surface Area:
750mm² X 67.5mm
= 50625mm³
67.5mm(W) X 130mm(L)
X 15mm(H) + SSR
Weight : @ 160gms

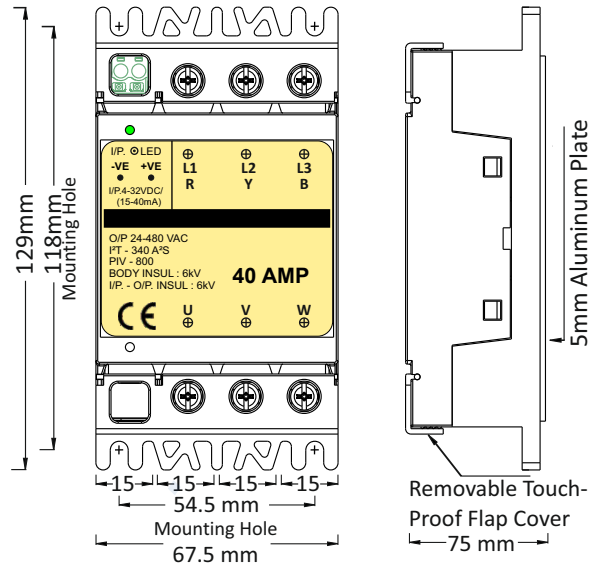

- Zero Voltage Turn-On .
- Rating from 25 Amp to 50 Amp @25°C 24-480 VAC.
- Short Circuit Current Rating As Per UL508A.
- Short Circuit Protected SSR up to 15 Amp per phase current by help of suitable "B" curve MCB.
- No need to use semiconductor Fuse due to short circuit protected SSR.
- With easy open & lock IP 20 protection Flaps on O/P Terminals.
- Fire Retardant Plastic as per UL94 VO GRADE.
- New improved SEMS Screw - Washers input & Output terminals.
- High resistance to aggressive chemicals and dust due to special Potting.
- Logic compatibility, Fast switching, Low coupling capacitance.
- No electromechanical or acoustical noise
- Long life cycle . Up to 10¹¹cycles
- No contact arcing, low electromagnetic interference, high surge capability
- SSRs can be provided as surface-mount technology, (SMT)parts, which means lower cost and easier SMT printed-circuit board manufacture

ORDERING FORMAT

MODEL	XXX	X	X	X	XX	YYY	ZZ
		Z	D	A	48	25	01

BSN3F Model

D : DC Input
A : AC Output

Output Current Rating: 25, 40, 50
Control Input: 01 : 4-32 VDC

Output Voltage: 48: 24-480 VAC

EXAMPLES
BSN3F25U48T
BSN3F40U48S

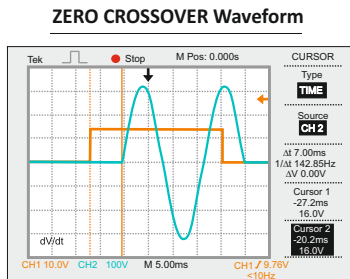

3 PH DC TO AC SSR BLOCK DIAGRAM

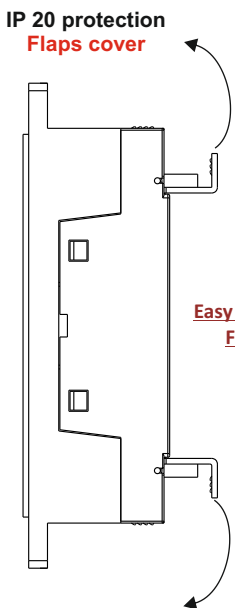
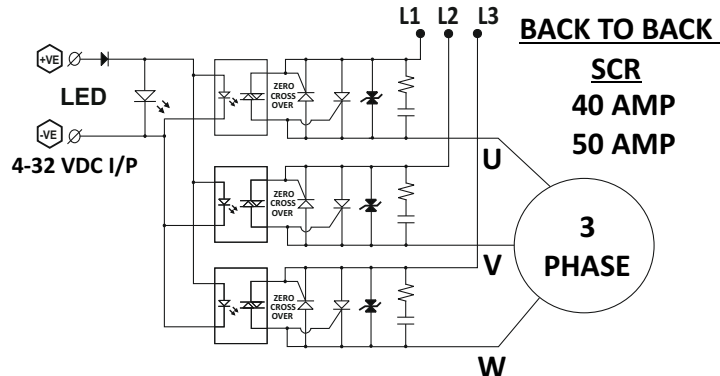
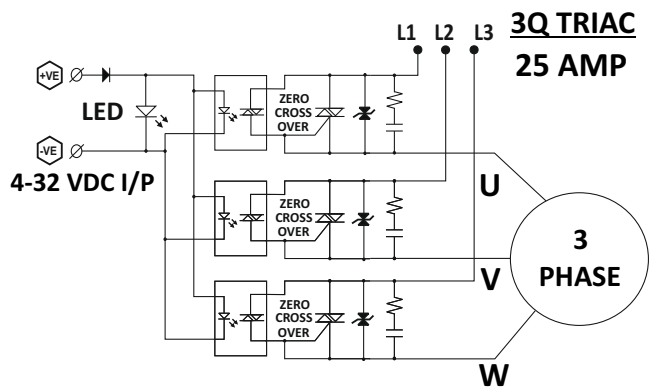

FIRE RETARDANT PLASTIC

General Specification	
Max Barrier Layer Temperature (T _{max})	< 125 °C
Ambient Temperature Range (T _{amb})	0-85 °C
SSR Storage Temperature Range (T _{st})	-40°C to 80°C
Input Terminal Screw Torque Range	T = 0.5 N.m (Max.)
Output Terminal Screw Torque Range	T = 2.5 N.m (Max.)
Power Factor COSφ @Max. Load @480VAC	> 0.55
Housing Material	UL-94 V0 Grade
Base Plate	Aluminium
SSR Weight	390 grams
Control Input Electrical Wire Size (Max.)	Up to 2.1 sq mm(14 AWG)
Power Output Electrical Wire Size (Max.)	Up to 25 sq mm(3 AWG)
Test Standards:	ROHS,IP20
Pending Approvals:	UL 508,VDE ,TUV ,CSA 22-2 IEC 60947-5-1:2016 IEC 62314:2006

Input Technical Specifications		
Parameters	Unit	ZDA
Control Voltage Range	V	4-32VDC
Input Frequency Range	Hz	-
Control Supply Current Consumption	mA	15-40mA
Input Impedance (Current Regulator Circuit Impedance)	Ω	0.3 kΩ - 1 kΩ
Minimum Turn ON Voltage	VDC	3.5 VDC
Turn OFF Voltage	VDC	< 3.5 VDC
Control Input Status Indication	-	Green LED Indication
Maximum Turn ON Time	mS	≤ 1/2 Cycle(10 mS)
Maximum Turn OFF Time	mS	≤ 1/2 Cycle(10 mS)

Output Technical Specifications @ 25°C Unless Specified					
Parameters	Symbol	Unit	25 Amp	40 Amp	50 Amp
Operating Voltage Range	V _{AC}	V _{RMS}	24-480 VAC - 3Q TRIAC	24-480 VAC B & B SCR	
Operating Frequency Range	f	Hz	47-63 Hz		
Peak Inverse Voltage	PIV	V _{PK}	800	1200	1200
Max. Surge Voltage With Stand Capacity (<1 Second)	V_{surge}	V_{RMS}	2700 V_{RMS} (3800 V_{PK})		
Rated Operational Current AC51a @ 20°C (Resistive Load)	I_T	Amp	25	40	50
Rated Operational Current AC53a @ 55°C (Inductive Load-Motor)	I _T	Amp	4.8	7.8	11.2
Maximum Load Short Circuit Protection Current @ 55°C	I_{SC}	Amp	-	9	15
"B" Curve D.P. MCB Rating for Short Circuit Protection	MCB	Amp	-	10	16
Maximum 3 Phase Motor Rating	hp	hp	2 hp	3 hp	5 hp
	kW	kW	1.49	2.23	3.72
NON Repetitive Surge Peak ON-State Current @ Rated V _{RRM} applied for 1/2 Cycle t=10 mS/t=8.33 mS (50 Hz/60 Hz)	I _{TSM} @ 50 Hz	Ap	260	460	800
	I _{TSM} @ 60 Hz		273	490	840
Max. I ² t for Fusing @ t=10 mS (50Hz)	I ² t	A ² s	340	1060	3000
Max. I ² t for Fusing @ t=8.33 mS (60Hz)	I ² t	A ² s	305	996	2750
Max. Peak ON-state voltage Drop	V _{TM}	V _{RMS}	≤ 1.2	≤ 1.2	≤ 1.2
Minimum Isolation Resistance between Input Terminals (+1,-2) to Output Terminals (L1,L2,L3,U,V,W) @ 500 VDC	Ω	GΩ	50	50	50
Isolation Voltage Input Terminals (+1,-2) to Output Terminals (L1,L2,L3,U,V,W) for 1 Minute	V _{ISO}	kV	6	6	6
Isolation Voltage Input & Output Terminal (+1,-2,L1,L2,L3,U,V,W) to Body Isolation for 1 Minute	V _{ISO}	kV	6	6	6
Phase to Phase Isolation between terminals (L1,L2,L3) to (U,V,W) for 1 Minute	V _{ISO}	kV	4	4	4
Max. Rate of Rise OFF-State Voltage	dV/dt	V/μS	1000	1000	1000
Max. Rate of Rise OFF-State Current	di/dt	A/μS	50	50	100
Max. Peak Repetitive Forward OFF-State Voltage	V _{DRM}	V	800	1200	1200
Max. Peak Repetitive Forward OFF-State current	I _{DRM}	mA	0.05	0.1	0.1
Max. Peak repetitive reverse off-state Voltage	V _{RRM}	V	800	1200	1200
Max. Peak repetitive reverse off-state current	I _{RRM}	mA	0.05	0.1	0.1
Max. DC Gate Trigger Voltage	V _{GT}	V	1.2	1.5	1.5
Max. DC Gate Trigger Current	I _{GT}	mA	50	50	50
Turn OFF Time	t _q	μS	20	50	120
Maximum Latching Current	I _L	mA	100	150	160
Maximum Holding Current	I _H	mA	75	75	150
Thermal Resistance R _θ (Junction to case)	R _{θ(j-c)}	°C/W	1.2	1.1	1
OFF State SSR Leakage Current @ Rated Voltage & Frequency (Snubber Leakage)	I _{leak}	mA	< 2 mA	< 2 mA	< 2 mA
SCCR Current Rating	I _{SCCR}	kA	-	-	10 kA
SSR Weight - 301 Model	W	gram	400	400	400

HEAT SINK TYPE "A-130" WITH FAN+ DIN RAIL

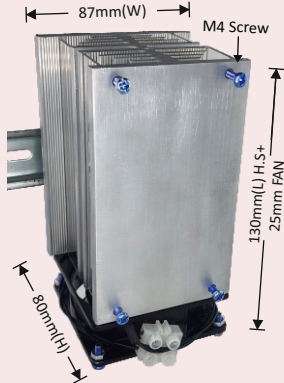

TYPE "A-130" WITH FAN
Model 301 - 1 Nos.
Current upto 120 Amp @ 40°C
with Din Rail 42mm
Thermal Resistance
 $\Delta T = 75^\circ\text{C}$
Surface Area:
 $2630\text{mm}^2 \times 130\text{mm}$
 $= 341900 \text{mm}^3$
 $87\text{mm(W)} \times 130\text{mm(L)}$
 $\times 80\text{mm(H)} + \text{SSR}$
Weight : @ 1150gms

HEAT SINK TYPE "A-130"+ DIN RAIL

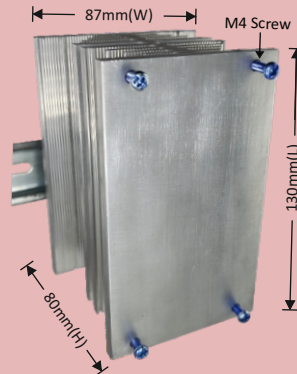

TYPE "A-130"
Model 301 - 1 Nos.
Current upto 105 Amp @ 40°C
with Din Rail 42mm
Thermal Resistance
 $\Delta T = 75^\circ\text{C}$
Surface Area:
 $2630\text{mm}^2 \times 130\text{mm}$
 $= 341900 \text{mm}^3$
 $87\text{mm(W)} \times 130\text{mm(L)}$
 $\times 80\text{mm(H)} + \text{SSR}$
Weight : @ 920gms

HEAT SINK TYPE "T-130" WITH FAN



TYPE "T-130"
Model 301 - 1 Nos.
Current upto 108 Amp @ 40°C
with Din Rail 42mm
Thermal Resistance
 $R_{\theta SA} = 2.35^\circ\text{C/W}$
 $R_{\theta SA} = 275.5 \text{K/W}$
 $\Delta T = 75^\circ\text{C}$
Surface Area:
 $2630\text{mm}^2 \times 130\text{mm}$
 $= 341900 \text{mm}^3$
 $87\text{mm(W)} \times 130\text{mm(L)}$
 $\times 80\text{mm(H)} + \text{SSR}$
Weight : @ 920gms

HEAT SINK TYPE "T-130" WITH OUT FAN

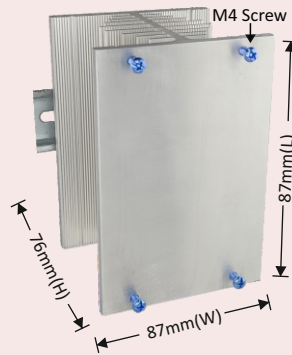

TYPE "T-130"
Model 301 - 1 Nos.
Current upto 96 Amp @ 40°C
with Din Rail 42mm
Thermal Resistance
 $R_{\theta SA} = 2.35^\circ\text{C/W}$
 $R_{\theta SA} = 275.5 \text{K/W}$
 $\Delta T = 75^\circ\text{C}$
Surface Area:
 $2630\text{mm}^2 \times 130\text{mm}$
 $= 341900 \text{mm}^3$
 $87\text{mm(W)} \times 130\text{mm(L)}$
 $\times 80\text{mm(H)} + \text{SSR}$
Weight : @ 920gms

HEAT SINK TYPE "D-67.5" + DIN RAIL

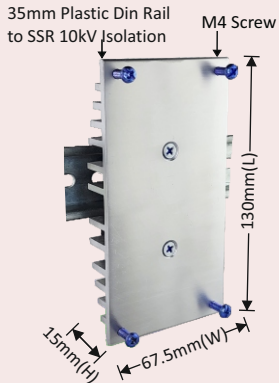

TYPE "D-67.5"
Model 301 - 1 Nos
Current upto 36 Amp @ 40°C
with Din Rail 42mm
Thermal Resistance
 $\Delta T = 75^\circ\text{C}$
Surface Area:
 $750\text{mm}^2 \times 67.5\text{mm}$
 $= 50625\text{mm}^3$
 $67.5\text{mm(W)} \times 130\text{mm(L)}$
 $\times 15\text{mm(H)} + \text{SSR}$
Weight : @ 160gms