

KT-1000D

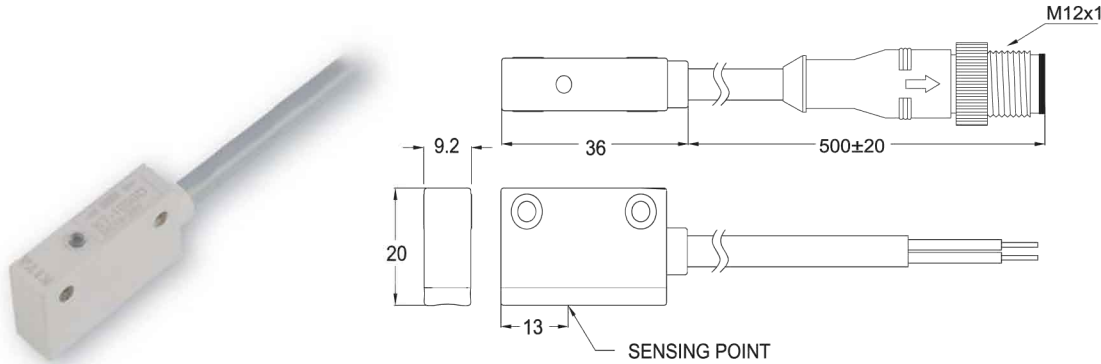

Magnetic switch

■ DIMENSION



Unit:mm

■ QD PINOUT

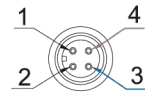

- 1:N/C (NO connect)
- 2:N/C (NO connect)
- 3:Blue
- 4:Brown

■ SPECIFICATION

TYPE	KT-1000D
CONNECT DIAGRAM	
CHARACTERISTICS	
WIRING METHOD	2-Wire Type
SWITCHING LOGIC	Solid State Output, Normally Open
SENSOR TYPE	--
OPERATING VOLTAGE	10~28 V DC
SWITCHING CURRENT	5-50 mA max.
CONTACT RATING (NOTE 1)	1.5 W max.
CURRENT CONSUMPTION	--
VOLTAGE DROP	5 V max.
LEAKAGE CURRENT	Less Than 1 mA
INDICATOR	Red LED : unstable sensing range Green LED : stable sensing range
CABLE	ø5.4, 2C, PVC
OPERATING TIME	50 ms max.
MAGNETIC FEILD RESISTANCE (NOTE 5)	16000A
MAGNET REQUIREMENT (NOTE 2)	80 Gauss
TEMPERATURE RANGE	-10~60°C
SHOCK (NOTE 3)	30 G
VIBRATION (NOTE 4)	9 G
ENCLOSURE CLASSIFICATION	IEC 529 IP 67
PROTECTION CIRCUIT	Surge Suppression, Reverse Polarity

NOTE:

1. WARNING: Never exceed rating (Watt=Voltage x Amperage). Permanent damage to sensor will occur.
2. Measuring standard target: ø15.5Xø8X5t (Anisotropy rubber magnet)
3. Sin wave / X , Y , Z 3 directions / 3 times each direction / 11 ms each time.
4. Double amplitude 1.5 mm / 10Hz~55Hz~10Hz (Sweep 1 min) / X , Y , Z 3 directions / 1 hour each time.
5. The operational distance can be 0 mm between KT-1000D and welding gun (welding conductor or cable) when the welding current less than 16000 A.

■ ORDERING INFORMATION

KT - 1000D -

Cable Length / Connector

- Blank:With 3 meter cable
- 2M:With 2 meter cable
- 4M:With 4 meter cable
- QD : With M12, 4 Pin male connector

Mounting clamps

BP - 4045

Cylinder bore size

- 40: ø40
- 50: ø50
- 63: ø63

Cylinder tube outer diameter

- 45: ø45
- 47: ø47
- 55: ø55
- 58: ø58
- 68: ø68
- 72: ø72