

Dimensions

**BTC-59R, BTC-59N, BTC-59P, BTC-59RP /
BTC-59R-QD, BTC-59N-QD, BTC-59P-QD, BTC-59RP-QD**

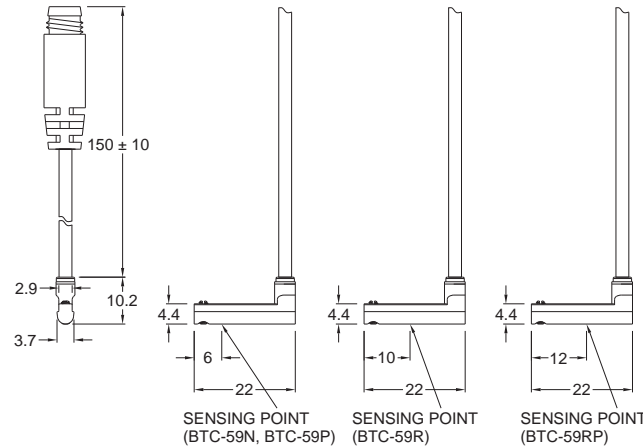

Unit : mm

QD Pinout

3 wire QD wiring

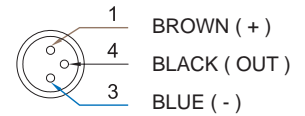

2 wire QD wiring

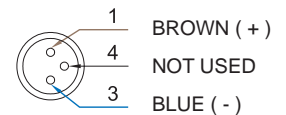

2 wire EQD wiring

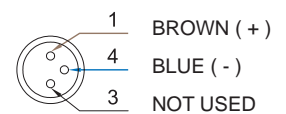

Specifications

MODEL	BTC-59R	BTC-59N	BTC-59P	BTC-59RP
Connect Diagram				
Characteristics				
Wiring Method	2-Wire Type	3-Wire Type		
Switching Logic	SPST, Normally Open	Solid State Output, Normally Open		SPST, Normally Open
Sensor Type	Reed Switch	NPN Current Sinking	PNP Current Sourcing	Reed Switch
Operating Voltage	5 ~ 120 V DC / AC	10 ~ 30 V DC		10 ~ 30 V DC / AC
Switching Current	100 mA max.	200 mA max.		500 mA max.
Contact Rating *1	10 W max.	6 W max.		10 W max.
Current Consumption	-	10 mA @ 24 V DC max.		5 mA @ 24 V DC max.
Voltage Drop	3.5 V max.	0.5 V @ 50 mA max.		0.1 V @ 100 mA max.
Leakage Current	-	0.01 mA max.		-
Indicator	Red LED		Yellow LED	
Cable	ø2.5, 2C, PUR	ø2.5, 3C, PUR		
Operating Frequency	200 Hz	1000 Hz		200 Hz
Magnet Requirement *2	70 Gauss	40 Gauss		50 Gauss
Temperature Range	-10 ~ 70 °C			
Shock *3	30 G	50 G		30 G
Vibration *4	9 G			
Enclosure Classification	IEC 60529 IP67			
Protection Circuit *5	1	3, 4		1

NOTE:

*1 : WARNING : Never exceed rating (Watt = Voltage x Amperage).
Permanent damage to sensor will occur.

*2 : Measuring standard target : ø15.5 × ø8 × 5t (Anisotropy rubber magnet)

*3 : Sin wave / X , Y , Z 3 directions / 3 times each direction / 11 ms each time.

*4 : Double amplitude 1.5 mm / 10 Hz ~ 55 Hz ~ 10 Hz (Sweep 1 min) / X , Y , Z 3 directions / 1 hour each time.

*5 : 1 = None / 2 = Short-circuit / 3 = Power Source Reverse polarity / 4 = Surge Suppression

Groove Dimensions

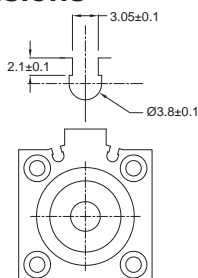

Unit : mm