

Three phase tachogenerator

TD 3 A 4 KA ...



Qualities:

- Cost effective
- Without coupling
- Absolute maintenance - free
- Safe to operate
- 5 years guarantee
- Spacious cable box

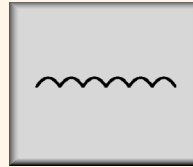

TD



DTD

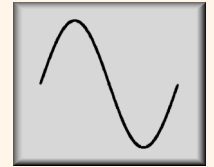

WTD

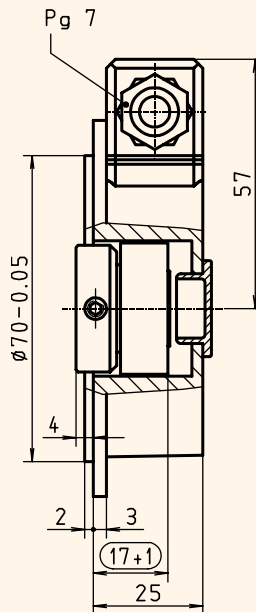

output alternatively left or right

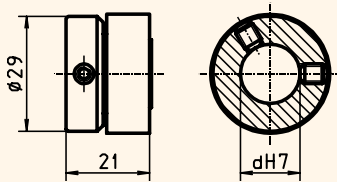
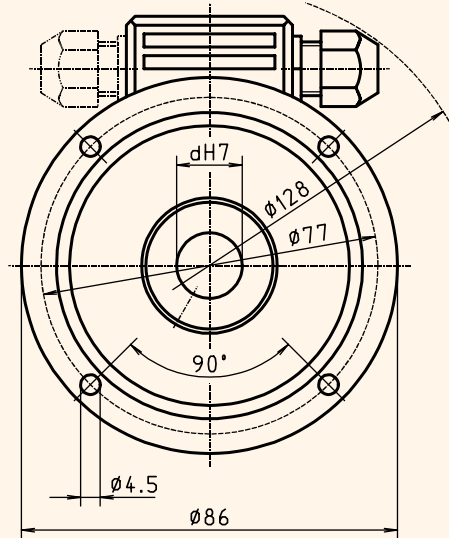

TD 3 A 4 KA RM drawing-no.: 019 - 16

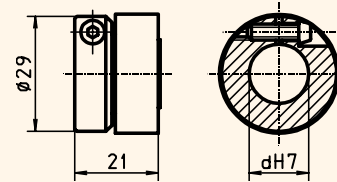

TD 3 A 4 KA KM drawing-no.: 020 - 2

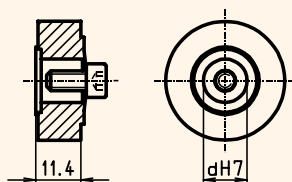

TD 3 A 4 KA AM drawing-no.: 020 - 6

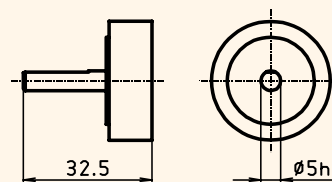
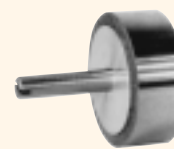

TD 3 A 4 KA SM drawing-no.: 020 - 7

Three phase tachogenerator

TD 3 A 4 KA ...



Mechanical data:

Housing		light - alloy metal, unpainted
Design class		A 4
Protective class		IP 66 <i>according to DIN 40 050, IEC 529</i>
Upper speed limit	n_{max}	≤ 12000 rpm
Rotor attachment		AM, KM, RM, SM
Hollow shaft diameter	d	14 mm, 15 mm (standard) (6 - 16 mm possible)
Mass moment of inertia	J	70 gcm ²
Weight	<i>housing</i>	approx. 270 g
	<i>rotor</i>	approx. 50 g

Electrical data:

Output voltage	(no - load)	U_0	30 VDC \pm 3 %
Polarity			independent on rotational direction
max. output current		I_{max}	20 mA
Magnet			Al Ni Co, 8-pole, stabilized
Residual ripple			≤ 15 % peak - peak
Residual ripple frequency			400 Hz $f = 0,4 * n$
Linearity error		$F_{Regulation}$	≤ 1 %
Linearity error		$F_{Regression}$	$\pm 0,1$ % (100 rpm < $n \leq 1000$ rpm)
Regulation range lower limit		n_R	30 rpm
Temperature drift	(magnet)		- 0,2 % pro 10 K

referenced to 1000 rpm

Type of connection	terminal box, 2- pole
Isolation class	E
Operating temperature range	- 30 °C to + 120 °C
Maintenance	maintenance - free

Options:

- Output voltage (no - load) < 30 VDC
- Balancing to rated voltage for example 30 VDC at 12 k Ω load (2,5 mA)
- Three phase output **DTD** with or without cable
- alternating current output **WTD** with or without cable
- Double winding with or without cable
- Pole reverser for 4 - quadrant operation TD 3... P max. 3000 rpm / only for KM and RM magnets
- Enhanced protective class
- Hollow shaft diameter d 10 mm, 11 mm, 12 mm, 16 mm

Load characteristic:

