

# BS1F SERİSİ DC-DC SOLID STATE RELAY

OUTPUT DC CONTROL COOL POWER MOSFET & IGBT CONTROL TECHNOLOGY

## PMDD (POWER MOSFET)

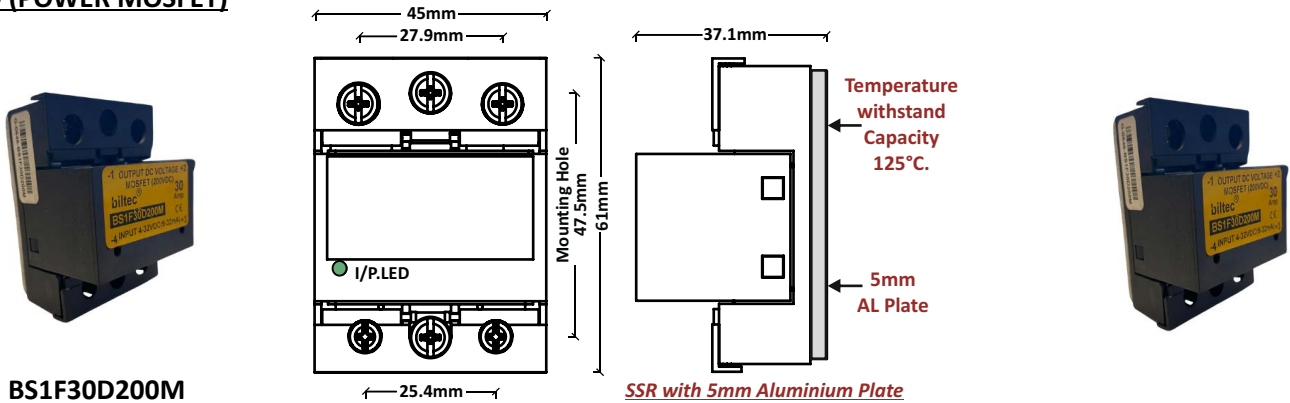

BS1F30D200M

SSR with 5mm Aluminium Plate

### ORDERING FORMAT

PM : POWER MOSFET  
IG : IGBT

D : DC Output

Control Input  
00 : 4-32 VDC

D : DC Input

Output Voltage

Output Current Rating

PM: POWER MOSFET		IG: IGBT	
Output Voltage	Output Current Rating	Output Voltage	Output Current Rating
30: 5-30 VDC	50 A	600: 5-600 VDC	10 A
30: 5-30 VDC	100 A	600: 5-600 VDC	20 A
60: 5-60 VDC	30 A	1200: 5-1200 VDC	10 A
60: 5-60 VDC	60 A	1200: 5-1200 VDC	20 A
85: 5-85 VDC	45 A		
85: 5-85 VDC	90 A		
200: 5-200 VDC	20 A		
200: 5-200 VDC	30 A		

EXAMPLES  
BS1F30D200M

- Product Temperature withstand 125°C.
- PWM capacity 100 Hz.
- With easy open & lock IP 20 protection Flaps on I/P & O/P Terminals.
- Switching Speeds are Inherently Faster.
- No need to De-rate Power Handling Capacity.
- Input LED Green Indication.
- Isolated Drivers, Low Power Transient.
- N/O Configurations only.
- Reverse Polarity Protection on Input Side.
- Power (Pd) Increases with Case Temperature Increase.
- Junction Temperature Increases with R<sub>ds</sub> Increase.

### PMDD- POWER MOSFET DC TO DC

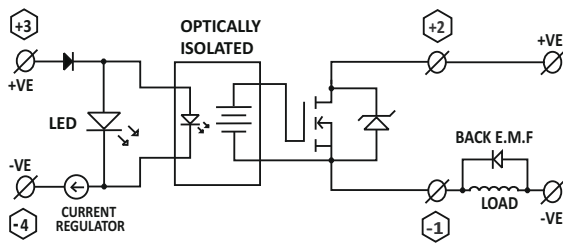

- Ultra Low ON state resistance - MOSFET
- RDS (ON) has Positive Temperature Co-efficient which aids in paralleled Power MOSFET device and Negative Temperature Co-efficient of Trans-Conductance so less susceptible for Thermal Runway.
- Voltage Range available from 30V to 200V (Low Voltage application)

### IGBT- Insulated Gate Bipolar Transistor DC TO DC

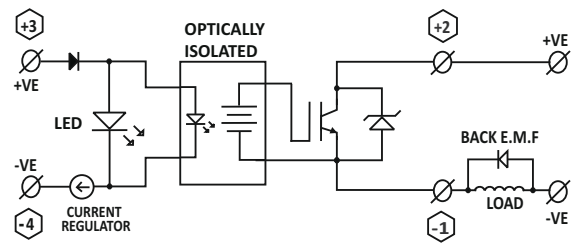

- Ultra Low Output Leakage current - IGBT
- Higher Short Circuit current rating (I<sub>sc</sub>).
- Voltage Range available from 600V to 1200V (High Voltage application)

TURN ON Time 250µs Waveform of Power MOSFET

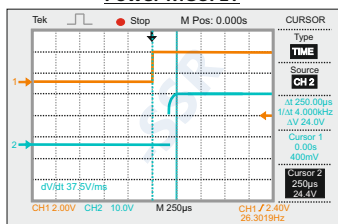

TURN OFF Time 30µs Waveform of Power MOSFET

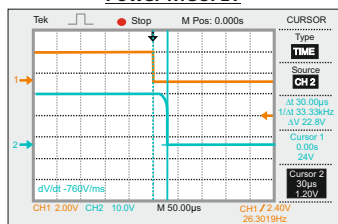

TURN ON Time 250µs Waveform of IGBT

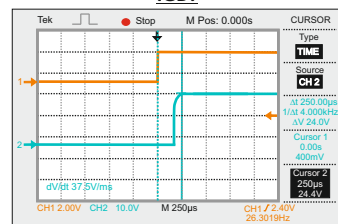

TURN OFF Time 30µs Waveform of IGBT

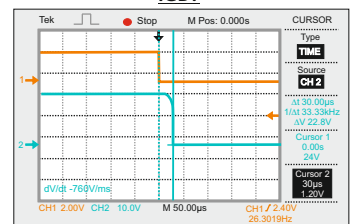

**General Specification**

	< 125 °C
Ambient Temperature Range ( $T_{amb}$ )	0-85 °C
SSR Storage Temperature Range ( $T_{st}$ )	-40°C to 80°C
Input Terminal Screw Torque Range	$T = 1.6$ N.m (Max.)
Output Terminal Screw Torque Range	$T = 2.5$ N.m (Max.)
Housing Material	UL-94 V0 Grade
Base Plate	Aluminium
SSR Weight	100 grams
Control Input Electrical Wire Size ( Max. )	4 mm <sup>2</sup>
Power Output Electrical Wire Size ( Max. )	25 mm <sup>2</sup>
Test Standards:	ROHS,IP20

**Input Technical Specifications**

Parameters	Unit	Type Selection	
		PMDD	IGBT
Control Voltage Range	V	4-32 VDC	4-32 VDC
Reverse Polarity Protection	-	YES	YES
Input Frequency Range(PWM)	Hz	Up to 100Hz	Up to 100Hz
Control Supply Current Consumption	mA	9-32 mA	9-32 mA
Input Impedance (Current Regulator Circuit Impedance)	$\Omega$	0.5k $\Omega$ - 1k $\Omega$	0.5k $\Omega$ - 1k $\Omega$
Minimum Turn ON Voltage	VDC	3.5 VDC	3.5 VDC
Turn OFF Voltage	VDC	< 3.5 VDC	< 3.5 VDC
Control Input Status Indication	-	Green LED Indication	

**THERMAL DERATING CURVE WITH HEAT SINK**

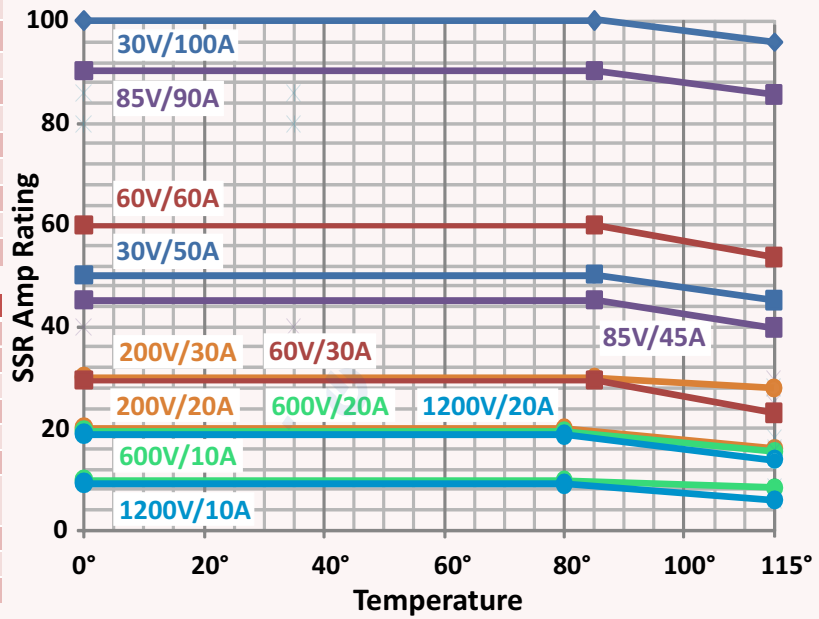

**Output Technical Specifications @ 25°C Unless Specified - FOR POWER MOSFET**

Parameters	Symbol	Unit	30V /	30V /	60V /	60V /	85V /	85V /	200V /	200V /
			50Amp	100Amp	30Amp	60Amp	45Amp	90Amp	20Amp	30Amp
Output Circuit - Switching Element			<b>POWER MOSFET</b>							
Operating Output DC Voltage Range	V	VDC	5-30	5-30	5-60	5-60	5-85	5-85	5-200	5-200
Maximum Drain To Source Break Down Voltage	$I_b$	Amp	50	100	30	60	45	90	20	30
Static Drain To Source ON Resistance	$V_{(BR)DSS}$	VDC	30	30	60	60	85	85	200	200
<b>Safe Continuous Drain Current @ <math>T_c=55^\circ\text{C}</math> with Suitable Heat Sink</b>	$R_{DS(ON)}$	m $\Omega$	1.6	0.8	4.1	2	2.8	1.4	15	7.5
On state Voltage Drop @ Rated Current	$V_{DS}$	VDC	< 0.4	< 0.4	< 0.7	< 0.7	< 0.3	< 0.3	< 0.9	< 0.9
Pulse Drain Current (less than 60 $\mu\text{s}$ )	$I_{DM}$	Amp	1000	2000	200	500	800	1600	100	300
Required minimum LOAD current	$mA_{DC}$	mA	3	3	3	3	3	3	3	3
SSR Turn ON Delay Time (Response Time)	$T_{D(ON)}$	$\mu\text{s}$	192	202	192	58	228	280	100	48
SSR Turn Off Delay Time	$T_{D(OFF)}$	$\mu\text{s}$	18	22	22	22	22	22	34	32
Minimum Isolation Resistance between Input Terminals (+I/P,-I/P) to Output Terminals (-O/P,+O/P) @ 500 VDC	$\Omega$	G $\Omega$	1	1	1	1	1	1	1	1
Isolation Voltage Input Terminals (+3,-4) to Output Terminals (-1,+2) for 1 Minute	$V_{ISO}$	kV	2.5	2.5	2.5	2.5	2.5	2.5	2.5	2.5
Isolation Voltage Input & Output Terminal (+3,-4,-1,+2) to Body Isolation for 1 Minute	$V_{ISO}$	kV	2.5	2.5	2.5	2.5	2.5	2.5	2.5	2.5
Maximum Junction Temperature	$T_{j(max)}$	°C	125 °C							
Thermal Resistance $R_{\theta}$ (Junction To Case)	$R_{\theta(j-c)}$	°C/W	1.65	0.45	0.7	0.1	3.1	1.15	0.7	0.9

**Output Technical Specifications @ 25°C Unless Specified - FOR IGBT**

Parameters	Symbol	Unit	600V /	600V /	1200V /	1200V /
			10Amp	20Amp	10Amp	20Amp
Output Circuit - Switching Element			<b>IGBT</b>			
Operating Output DC Voltage Range	V	VDC	5-600	5-600	5-1200	5-1200
<b>Safe Continuous Collector Current @ <math>T_c=55^\circ\text{C}</math> with Suitable Heat Sink</b>	$I_c$	Amp	10	20	10	20
Maximum Collector To Emmitter Voltage	$V_{CES}$	VDC	600	600	1200	1200
Short Current	$I_{SC}$	Amp	75	75	75	75
On state Voltage Drop @ Rated Current	$V_{CESAT}$	VDC	< 1.8	< 1.8	< 2	< 2
Required minimum LOAD current	$mA_{DC}$	mA	3	3	3	3
SSR Turn ON Delay Time	$T_{D(ON)}$	$\mu\text{s}$	86	146	436	860
SSR Turn Off Delay Time	$T_{D(OFF)}$	$\mu\text{s}$	22	22	22	22
Minimum Isolation Resistance between Input Terminals (+I/P,-I/P) to Output Terminals (-O/P,+O/P) @ 500 VDC	$\Omega$	G $\Omega$	1	1	1	1
Isolation Voltage Input Terminals (+I,-I) to Output Terminals (-O/P,+O/P) for 1 Minute	$V_{ISO}$	kV	2.5	2.5	2.5	2.5
Isolation Voltage Input & Output Terminal (+I/P,-I/P,-O/P,+O/P) to Body Isolation for 1 Minute	$V_{ISO}$	kV	2.5	2.5	2.5	2.5
Maximum Junction Temperature	$T_{j(max)}$	°C	125 °C			
Thermal Resistance $R_{\theta}$ (Junction To Case)	$R_{\theta(j-c)}$	°C/W	0.7	0.35	0.3	0.2

**TYPE OF HEATSINKS / CURRENT RATING / RθSA / SURFACE AREA / MECHANICAL DIMENSIONS / WEIGHT**

**HEAT SINK TYPE "C-56" + DIN RAIL**

35mm Plastic Din Rail to SSR 10kV Isolation  
M4 Screw

**TYPE "C-56"**  
Model 901-1 Nos.  
Current upto **16Amp @40°C**  
with Din Rail 42mm,  
Thermal Resistance  
RθSA = 4°C/W  
RθSA = 277.15 K/W  
ΔT= 75°C  
Surface Area:  
353mm<sup>2</sup>×56mm  
=19768mm<sup>3</sup>  
43mm(W)×56mm(L)  
x 13.5mm(H) + SSR  
Inbuilt Heat Sink IN 901 SSR MODEL Weight : @ 57gms  
No Separate Heat Sink available

**HEAT SINK TYPE "G-68" + DIN RAIL**

35mm Plastic Din Rail to SSR 10kV Isolation  
M3 Screw

**TYPE "G-68"**  
Model 901-1 Nos.  
Model 808-1 Nos.  
Current upto **26Amp @40°C**  
with Din Rail 22.5mm,  
Thermal Resistance  
RθSA = 2.5°C/W  
RθSA = 275.65 K/W  
ΔT= 75°C  
Surface Area:  
491mm<sup>2</sup>×68mm  
=33388 mm<sup>3</sup>  
44mm(W) X 68mm(L)  
X 32mm(H) + SSR  
Weight : @ 95gms

**HEAT SINK TYPE "B-48" + DIN RAIL**

35mm Plastic Din Rail to SSR 10kV Isolation  
M4 Screw

**TYPE "B-48"**  
Model 803-Upto 2 Nos.  
Model 901-1 Nos.  
Current upto **36Amp @40°C**  
with Din Rail 42mm  
Thermal Resistance  
RθSA = 1.17°C/W  
RθSA = 274.32 K/W  
ΔT= 75°C  
Surface Area:  
2630mm<sup>2</sup>×48mm  
=126240 mm<sup>3</sup>  
48mm(W) X 87mm(L)  
X 80mm(H) + SSR  
Weight : @ 310gms

**HEAT SINK TYPE "B-72" + DIN RAIL**

35mm Plastic Din Rail to SSR 10kV Isolation  
M4 Screw

**TYPE "B-72"**  
Model 803-Upto 3 Nos.  
Model 901-1 Nos.  
Current upto **60Amp @40°C**  
with Din Rail 42mm  
Thermal Resistance  
RθSA = 0.85°C/W  
RθSA = 274 K/W  
ΔT= 75°C  
Surface Area:  
2630mm<sup>2</sup>×72mm  
=189360 mm<sup>3</sup>  
72mm(W) X 87mm(L)  
X 80mm(H) + SSR  
Weight : @ 500gms

**UL-94 VO GRADE  
FIRE RETARDANT PLASTIC**

**Solenoid Valve / DC Load Application**

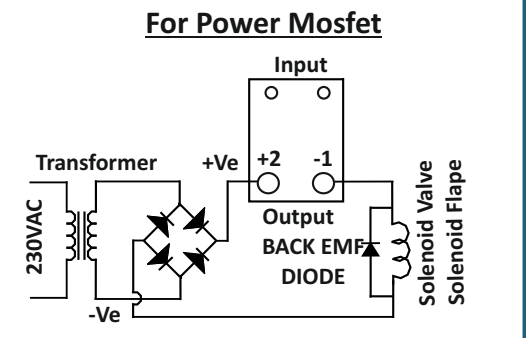

**HEAT SINK SELECTION GUIDE**

901 MODEL / HEAT SINK	PMDD								IGDD			
	30V / 50Amp	30V / 100Amp	60V / 30Amp	60V / 60Amp	85V / 45Amp	85V / 90Amp	200V / 20Amp	200V / 30Amp	600V / 10Amp	600V / 20Amp	1200V / 10Amp	1200V / 20Amp
C-56	20 Amp	-	20 Amp	-	20 Amp	-	10 Amp	-	-	-	-	-
G-68	30 Amp	-	30 Amp	-	30 Amp	-	20 Amp	30 Amp	10 Amp	-	10 Amp	-
B-48	50 Amp	-	-	60 Amp	45 Amp	60 Amp	-	-	-	20 Amp	-	20 Amp
B-72	-	100 Amp	-	-	-	90 Amp	-	-	-	-	-	-

\* All above SSR Rating & Heat Sink Selections are considered on environment temperature @ 55°C

**30AMP - MODEL BS1F**

Max. 35Sqmm Lugs

H.S Mounting  
47.5MM  
68mm(L)

Weight: 110gms SSR + 95gms G-68 Heat sink

# APPLICATIONS

